

JBC
The Soldering Co.

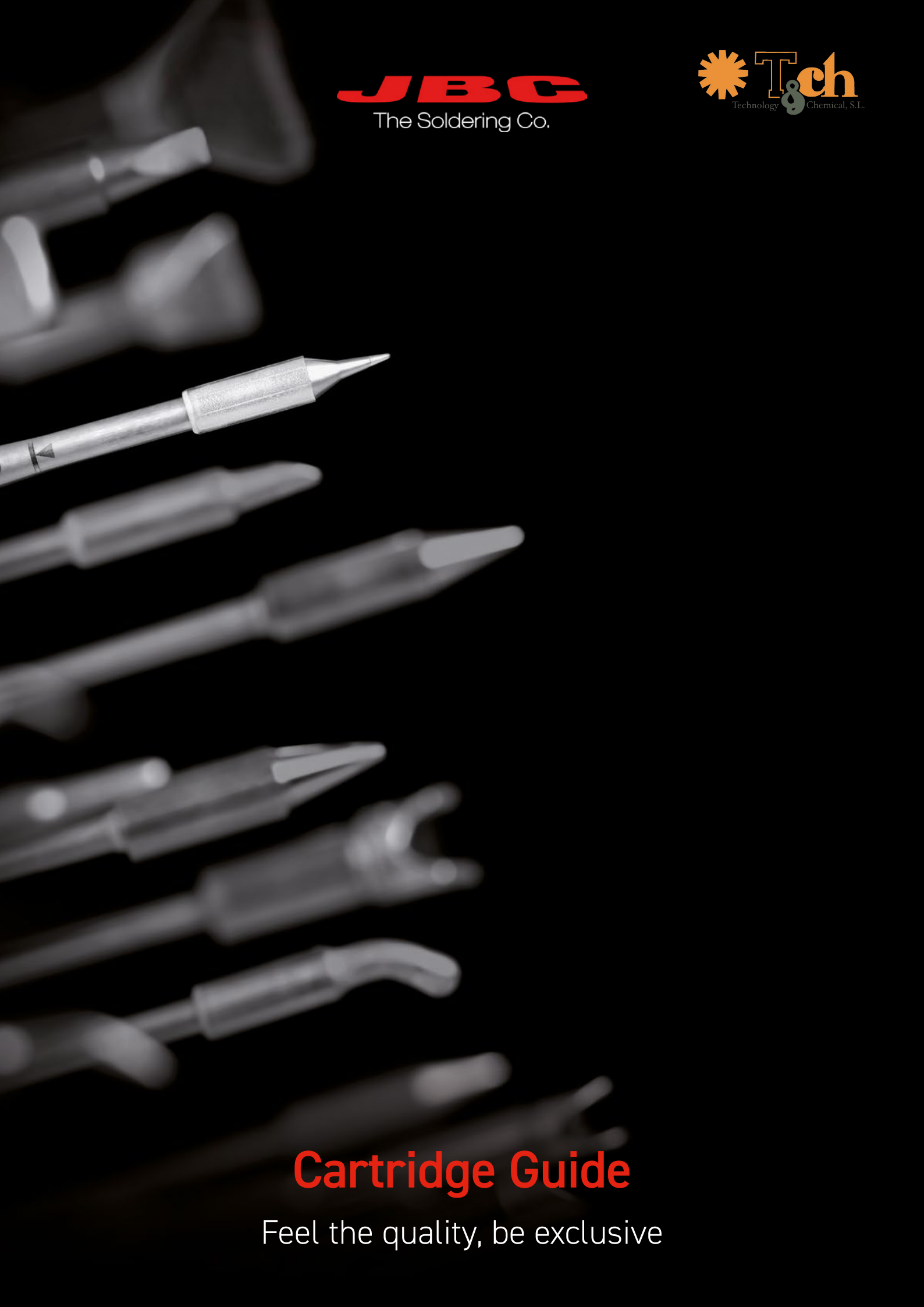

Cartridge Guide

Feel the quality, be exclusive

JBC Technology

Most Efficient Soldering System

JBC Stations work with JBC Most Efficient Soldering System, which **recovers tip temperature extremely quickly**. This increases work efficiency and allows the user to work with lower temperatures.

Efficient Temperature Control
Comparative process of 3 solder joints

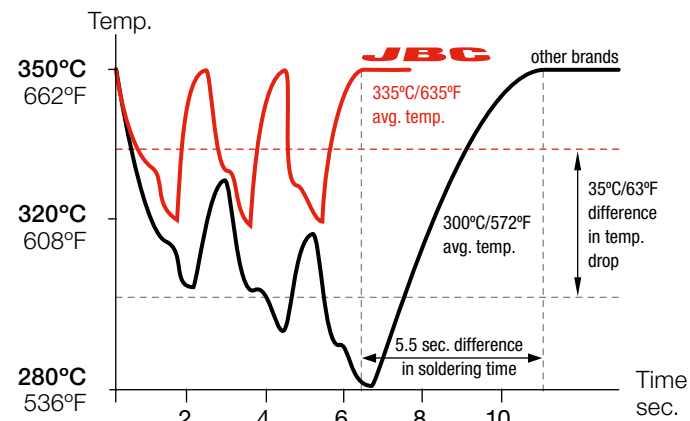

Tips with JBC Technology only drop 30°C (54°F) where others drop as much as 70°C (126°F).

Enhanced Temperature Efficiency → Increased Productivity + Better Quality

Productivity

Short tip-to-sensor distance ensures extremely quick temperature recovery and an **accurate control**.

Heating System Principles
350°C/662°F in 2 seconds

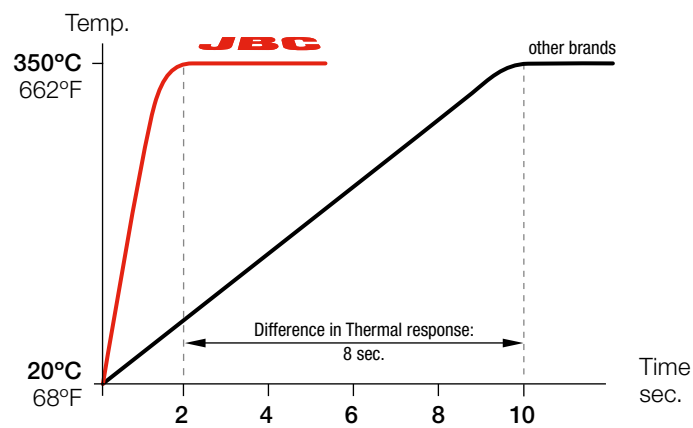

This graph compares JBC C210 Cartridge Range to the equivalent cartridges of the best competitor.

Intelligent Heat Management

Thanks to automatic detection of the tool in the stand, JBC Soldering & Rework Stations allow the tools to enter **Sleep & Hibernation Modes** when not being used. As a result, tip life lasts up to 5 times longer.

Sleep Mode

Sleep Mode **automatically lowers tip temperature** below the solder melting point when the tool rests in the stand. **It prevents the dissolution of the iron tip coating into molten solder.**

Hibernation Mode

After a configurable period of tool inactivity in the stand, the tool enters Hibernation Mode. **It cuts off the power supply** making the tip reach room temperature, thus **preventing oxidation and saving energy.**

Longer Tip life

Tip life increases exponentially by **using lower temperatures** as shown. Using Sleep Mode, the temperature is further reduced, which **multiplies tip life by 5.**

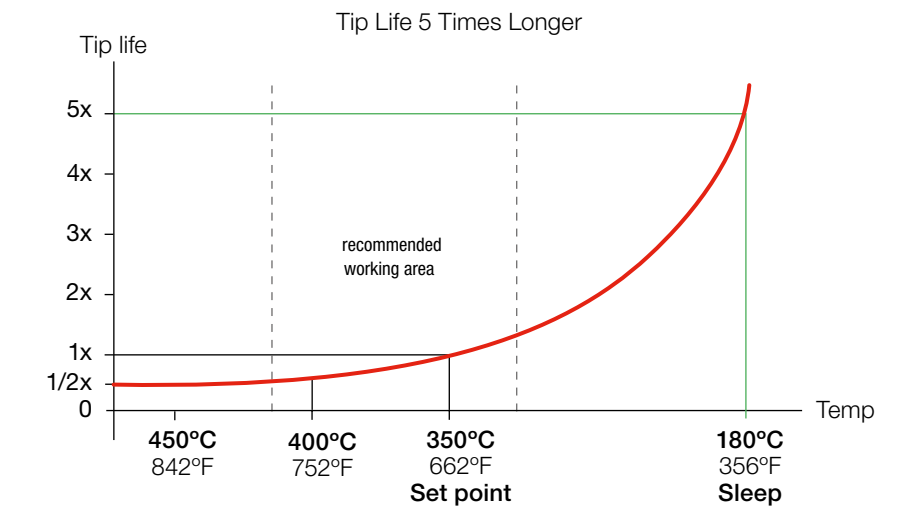
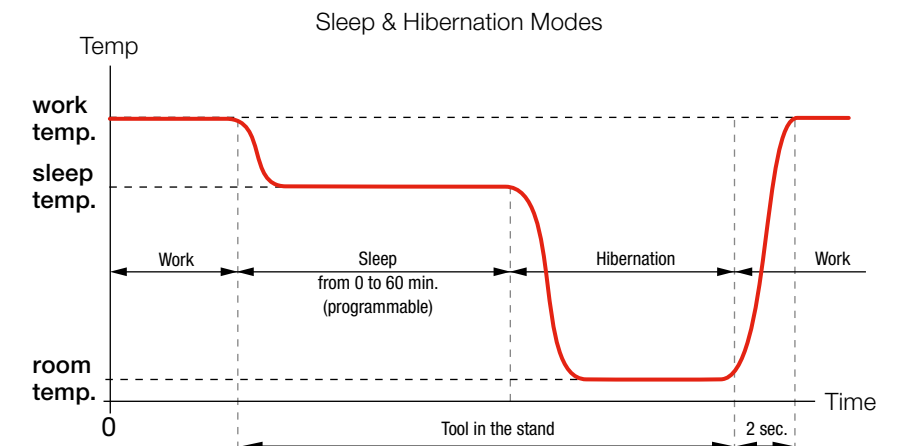

Cartridges with long life & extended tip life

The essential part of the soldering iron is the tip. Therefore, JBC has **over 500 cartridge models of different shapes and sizes** to choose from, depending on each application. JBC has developed the most advanced technology based on the following principles:

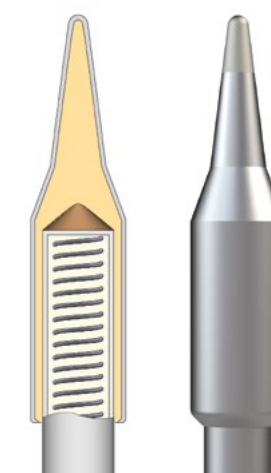

- **Excellent Heat Transfer**
The compact element reduces thermal barriers.
- **Instantaneous Heating**
A fully-integrated thermal sensor in the heater ensures quick temperature recovery.
- **Great Durability**
The intelligent algorithm control program extends tip life.

A global organization at your service

JBC is a global company with a distributor network spanning 5 continents that guarantees a solid commercial organization with quick and efficient service.

The power of experience

More than 90 years of experience have placed JBC at the technological forefront of tools for soldering and rework operations in electronics. Innovation, efficiency and reliability are the key features of a wide range of products which have been designed to satisfy the most demanding requirements of professionals.

High technology, superior quality

Product perfection is one of the main objectives of JBC's improvement and development program. The R&D department has created the most innovative soldering technologies, which JBC is proud to present in this catalogue.



All JBC products comply with CE standards and ESD recommendations.



When you start working do not forget:

Bigger is better

The bigger the solder tip, the better the thermal transfer. Select the tip that has the greatest contact area.

Over 500 tips of different sizes, shapes and power

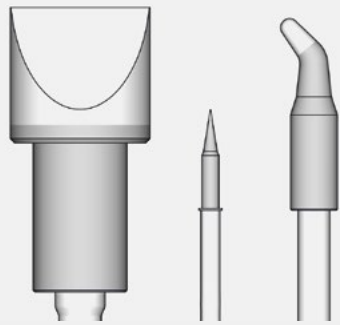

JBC Cartridges range from models for precision work to high power requirement applications.

Geometry Slimness vs Efficiency

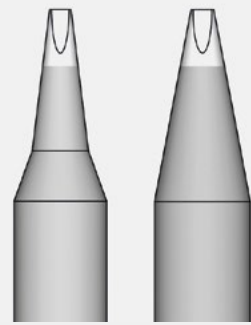

A tip with high-thermal efficiency makes your job up to **40% faster** than a tip with a slimmer geometry.

Increase the contact surface Tip - Application

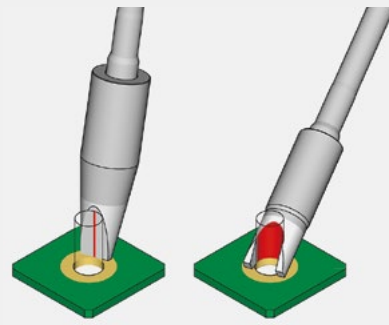

The bigger the contact surface that the tip has with the application, the higher the **thermal transfer**.

Largest mass possible

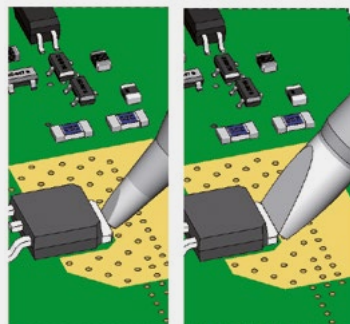

The more mass the tip has, the more heat is accumulated and the **lower is the temperature drop**.

Maintain tip surface clean and tinned



Remember that rusty and dirty surfaces reduce **heat transfer** to the solder joint.
(See JBC's cleaning methods on pages 8-9).

This way you will be able to:

- Work at **lower temperatures** (350°C / 662°F).
- Obtain **better results in less time**.
- Improve **thermal performance**.
- Increase **temperature precision**.
- Reduce **collateral damage** (thermal shock on components and PCBs).

Factors limiting tip life

Working temperature

The higher the temperature, the greater the oxidation and corrosion. Work with the **lowest possible temperature** and choose the tip with the greatest contact area for each application. **Use thermally efficient tools** and keep tips clean of oxidation.

Correct techniques

Too much pressure on the surface to solder can cause tip or plate breakage. Do not use the tip as a pointed object or a screwdriver. Choose the **right temperature and tip shape for each application**.

Iron plate thickness

Iron plate wear shortens tip life by hollowing tips out. Do not use mechanical or chemical means to clean the tip. Use the **cleaning methods provided by the manufacturer** - such as brass wool, automatic tip cleaner or sponges.

Oxidization

An oxidized soldering iron does neither wet nor transfer heat well (dewetting). The higher the temperature, the greater the risk of oxidation. **Always keep tips tinned while not in use** and take advantage of **JBC Sleep & Hibernation Modes**.

Flux and solder alloy

Too much active flux can cause corrosion. **IPC recommends: ROL, REL and ORL**. Flux quantity inside small diameter solder wires might not be enough. **Provide compatible external flux if necessary**.

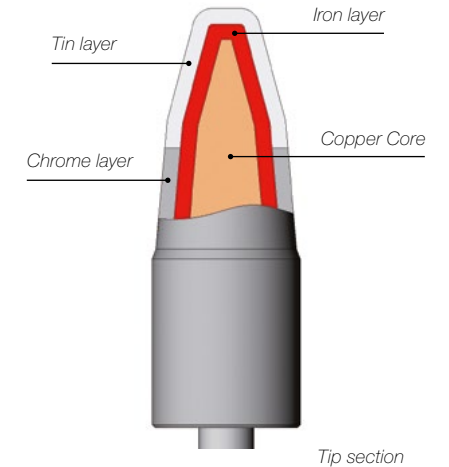

Tip section

Remember:

- Work with the **lowest possible temperature**.
- Use **thermally efficient tools**.
- Choose the **right temperature and tip shape for each application**.
- **IPC recommends: ROL, REL and ORL**.
- **Always keep tips tinned while not in use**.
- Take advantage of **JBC Sleep & Hibernation Modes**.
- **Too much pressure** on the surface to solder can cause **tip or plate breakage**.
- Use the **cleaning methods provided by the manufacturer**.



Cleaning Systems

For good thermal transfer, keep the tip tinned thus free from oxides.

Clean the tip in less than a second



With automatic cleaners you **save time** and optimize production.

Improve heat transfer

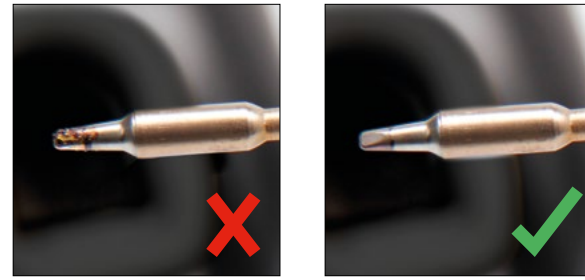

A clean tip is always easier to tin, resulting in **higher quality solder joints**.

CL Manual Tip Cleaner

A complete cleaning system with splashguard and antisplash membrane to keep the workspace clean and free of solder particles.



Cleaning Methods

CL6210

Brass Wool

Very effective cleaning method. It leaves a small layer of solder on the tip to prevent oxidation between cleaning and rewetting.



S0354

Sponge

The least harmful cleaning method. Keep the sponge moist with distilled water when working to avoid tip wear.



CLMS Automatic Junior Tip Cleaner with Fiber Brushes (non-metal)

The ideal partner to any soldering station.

Two modes of operation

The motorized brushes start by pushing the button or by selecting the continuous mode.

Splashguard



Save space

You can easily fit the tip cleaner into your workspace thanks to its reduced size.

Brushes

CL4008

Fiber Brushes

The composition, size and thickness of the fibers ensure the **most efficient cleaning** and the least damage while cleaning the tip.



Automatic Tip Cleaners

CLMUP

Automatic Tip Cleaner with Fiber Brushes (non-metal)

Perform a thorough and **gentle tip cleaning** increasing heat transfer and maximizing the soldering quality.

CLMU

Automatic Tip Cleaner with Metal Brushes

Perform a thorough and **strong cleaning** to recover the tip increasing heat transfer. The metal brushes supplied provide a **deep cleaning**.



Sensor Mode

The sensor triggers brush rotation when tip approaches and automatically stops when the tip is removed.



Vertical position

It also features a second position which facilitates vertical tip access.



Keep your workspace clean

The locking mechanism on the brushes makes them **fast and easy to replace**.

The solder collector tray can be **easily emptied**.



Brushes

CL2008 / CL2007

Fiber Brushes

provide a **soft cleaning**, especially recommended for regular usage to improve tip life. Supplied with CLMUP.



CL1008 / CL1007

Metal Brushes

provide a **thorough cleaning to recover the tip**, increasing heat transfer. Supplied with CLMU.





Our Cartridge Range is steadily growing as we are determined to respond to our clients' specific needs, cooperating closely with them to create **the right solution.**



C210 Cartridge Range for T210, B-100 and B-500 Handles

	Ref.	Description	Image and dimensions	Suggested components	Compatible with
	C210020	Conical Cartridge Ø 0.1 mm Ø 0.004 in		Package 01005, 0201 Very fine pitch 0.4 mm QFP, IC	Stations: CDS, DI, DDE, DME, B-IRON 100 / 500 Tools: T210, T210P, T210N, B-100, B-500
	C210009	Conical Cartridge Ø 0.2 mm Ø 0.008 in		Package 01005, 0201 Very fine pitch 0.4mm QFP, IC	Stations: CDS, DI, DDE, DME, B-IRON 100 / 500 Tools: T210, T210P, T210N, B-100, B-500
	C210016	Conical Cartridge Ø 0.3 mm S1 Ø 0.012 in		Package 0201, 0402 Fine pitch 0.65 mm QFP, IC	Stations: CDS, DI, DDE, DME, B-IRON 100 / 500 Tools: T210, T210P, T210N, B-100, B-500
	C210001	Conical Cartridge Ø 0.3 mm S2 Ø 0.012 in		Package 0201, 0402 Fine pitch 0.65 mm QFP, IC	Stations: CDS, DI, DDE, DME, B-IRON 100 / 500 Tools: T210, T210P, T210N, B-100, B-500
	C210013	Conical Cartridge Ø 0.5 mm Ø 0.020 in		Package 0603 QFP, IC	Stations: CDS, DI, DDE, DME, B-IRON 100 / 500 Tools: T210, T210P, T210N, B-100, B-500
	C210003	Conical Cartridge Ø 0.6 mm Ø 0.024 in		General use	Stations: CDS, DI, DDE, DME, B-IRON 100 / 500 Tools: T210, T210P, T210N, B-100, B-500
	C210005	Conical Cartridge Ø 1 mm Ø 0.039 in		General use	Stations: CDS, DI, DDE, DME, B-IRON 100 / 500 Tools: T210, T210P, T210N, B-100, B-500
	C210002	Conical Bent Cartridge Ø 0.2 mm Ø 0.008 in		Package 0201, 0402	Stations: CDS, DI, DDE, DME, B-IRON 100 / 500 Tools: T210, T210P, T210N, B-100, B-500

C210 Cartridge Range for T210, B-100 and B-500 Handles

	Ref.	Description	Image and dimensions	Suggested components	Compatible with
	C210010	Conical Bent Cartridge Ø 0.3 mm Ø 0.012 in		Package 0201, 0402 Fine pitch 0.65 mm QFP, IC	Stations: CDS, DI, DDE, DME, B-IRON 100 / 500 Tools: T210, T210P, T210N, B-100, B-500
	C210014	Conical Bent Cartridge Ø 0.5 mm Ø 0.020 in		Package 0603 QFP, IC	Stations: CDS, DI, DDE, DME, B-IRON 100 / 500 Tools: T210, T210P, T210N, B-100, B-500
	C210004	Conical Bent Cartridge Ø 0.7 mm Ø 0.028 in		General use	Stations: CDS, DI, DDE, DME, B-IRON 100 / 500 Tools: T210, T210P, T210N, B-100, B-500
	C210036	Bevel Cartridge Ø 0.6 mm Ø 0.024 in		Drag Soldering General use	Stations: CDS, DI, DDE, DME, B-IRON 100 / 500 Tools: T210, T210P, T210N, B-100, B-500
	C210006	Bevel Cartridge Ø 1 mm Ø 0.039 in		Drag Soldering General use	Stations: CDS, DI, DDE, DME, B-IRON 100 / 500 Tools: T210, T210P, T210N, B-100, B-500
	C210027	Bevel Cartridge Ø 1.5 mm Ø 0.059 in		Drag Soldering General use	Stations: CDS, DI, DDE, DME, B-IRON 100 / 500 Tools: T210, T210P, T210N, B-100, B-500
	C210031	Bevel Cartridge Ø 2 mm Ø 0.079 in		Drag Soldering General use	Stations: CDS, DI, DDE, DME, B-IRON 100 / 500 Tools: T210, T210P, T210N, B-100, B-500
	C210040	Bevel Cartridge Ø 2.9 mm Ø 0.114 in		Drag Soldering General use	Stations: CDS, DI, DDE, DME, B-IRON 100 / 500 Tools: T210, T210P, T210N, B-100, B-500
	C210028	Spoon Cartridge Ø 1 mm Ø 0.039 in		Drag soldering	Stations: CDS, DI, DDE, DME, B-IRON 100 / 500 Tools: T210, T210P, T210N, B-100, B-500

C210 Cartridge Range for T210, B-100 and B-500 Handles

Ref.	Description	Image and dimensions	Suggested components	Compatible with
C210029	Spoon Cartridge Ø 1.5 mm Ø 0.059 in		Drag soldering	Stations: CDS, DI, DDE, DME, B-IRON 100 / 500 Tools: T210, T210P, T210N, B-100, B-500
C210030	Spoon Cartridge Ø 2 mm Ø 0.079 in		Drag soldering	Stations: CDS, DI, DDE, DME, B-IRON 100 / 500 Tools: T210, T210P, T210N, B-100, B-500
C210038	Barrel Cartridge Ø 8 mm Ø 0.031 in		Through-hole Cable soldering / desoldering	Stations: CDS, DI, DDE, DME, B-IRON 100 / 500 Tools: T210, T210P, T210N, B-100, B-500
C210019	Chisel Cartridge 0.2 x 0.1 mm 0.008 x 0.004 in		Package 01005, 0201 Very fine pitch 0.4 mm QFP, IC	Stations: CDS, DI, DDE, DME, B-IRON 100 / 500 Tools: T210, T210P, T210N, B-100, B-500
C210023	Chisel Cartridge 0.4 x 0.2 mm 0.016 x 0.008 in		Package 0402 Very fine pitch 0.65 mm QFP, IC	Stations: CDS, DI, DDE, DME, B-IRON 100 / 500 Tools: T210, T210P, T210N, B-100, B-500
C210021	Chisel Cartridge 0.6 x 0.3 mm 0.024 x 0.012 in		Package 0603	Stations: CDS, DI, DDE, DME, B-IRON 100 / 500 Tools: T210, T210P, T210N, B-100, B-500
C210024	Chisel Cartridge 0.8 x 0.3 mm 0.032 x 0.012 in		Package 0805 Through-hole	Stations: CDS, DI, DDE, DME, B-IRON 100 / 500 Tools: T210, T210P, T210N, B-100, B-500
C210022	Chisel Cartridge 1.3 x 0.4 mm 0.051 x 0.016 in		Package 0805 Through-hole	Stations: CDS, DI, DDE, DME, B-IRON 100 / 500 Tools: T210, T210P, T210N, B-100, B-500
C210008	Chisel Cartridge 1.3 x 0.6 mm 0.051 x 0.024 in		Package 0805 Through-hole	Stations: CDS, DI, DDE, DME, B-IRON 100 / 500 Tools: T210, T210P, T210N, B-100, B-500

C210 Cartridge Range for T210, B-100 and B-500 Handles

Ref.	Description	Image and dimensions	Suggested components	Compatible with
C210007	Chisel Cartridge 2.3 x 0.7 mm 0.091 x 0.028 in		Package 0805 Through-hole	Stations: CDS, DI, DDE, DME, B-IRON 100 / 500 Tools: T210, T210P, T210N, B-100, B-500
C210039	Chisel Cartridge 2.9 x 0.7 mm 0.114 x 0.028 in		Package 0805 Through-hole	Stations: CDS, DI, DDE, DME, B-IRON 100 / 500 Tools: T210, T210P, T210N, B-100, B-500
C210017	Pin / Connector Cartridge Ø 0.7 mm Ø 0.028 in		Through-hole	Stations: CDS, DI, DDE, DME, B-IRON 100 / 500 Tools: T210, T210P, T210N, B-100, B-500
C210015	Pin / Connector Cartridge Ø 0.8 mm Ø 0.032 in		Through-hole Coaxial connector	Stations: CDS, DI, DDE, DME, B-IRON 100 / 500 Tools: T210, T210P, T210N, B-100, B-500
C210025	Pin / Connector Cartridge Ø 1.1 mm Ø 0.043 in		Through-hole Coaxial connector	Stations: CDS, DI, DDE, DME, B-IRON 100 / 500 Tools: T210, T210P, T210N, B-100, B-500
C210012	Pin / Connector Cartridge Ø 1 mm Ø 0.039 in		Cables Connectors	Stations: CDS, DI, DDE, DME, B-IRON 100 / 500 Tools: T210, T210P, T210N, B-100, B-500
C210033	Knife Cartridge 2.5 x 0.3 mm 0.098 x 0.012 in		Drag soldering SMD SO, SOT Package 1210, 1812, 2010, 2512	Stations: CDS, DI, DDE, DME, B-IRON 100 / 500 Tools: T210, T210P, T210N, B-100, B-500
C210018	Knife Cartridge 3.4 x 0.3 mm 0.134 x 0.012 in		Drag soldering SMD SO, SOT Package 1210, 1812, 2010, 2512	Stations: CDS, DI, DDE, DME, B-IRON 100 / 500 Tools: T210, T210P, T210N, B-100, B-500
C210034	Conformal Coating Removal Steel Cartridge 1 x 0.1 mm 0.039 x 0.004 in		Stainless Steel Remove underfill encapsulants	Stations: CDS, DI, DDE, DME, B-IRON 100 / 500 Tools: T210, T210P, T210N, B-100, B-500